

**RT70 SC/ H -3X STEERING
LATCH AND DOOR MOUNT
70 LBS THRUST
24 VOLT 42 AMPS
52" SHAFT**

**for use with "WWAF" serial numbers
3-year warranty from the date of purchase**

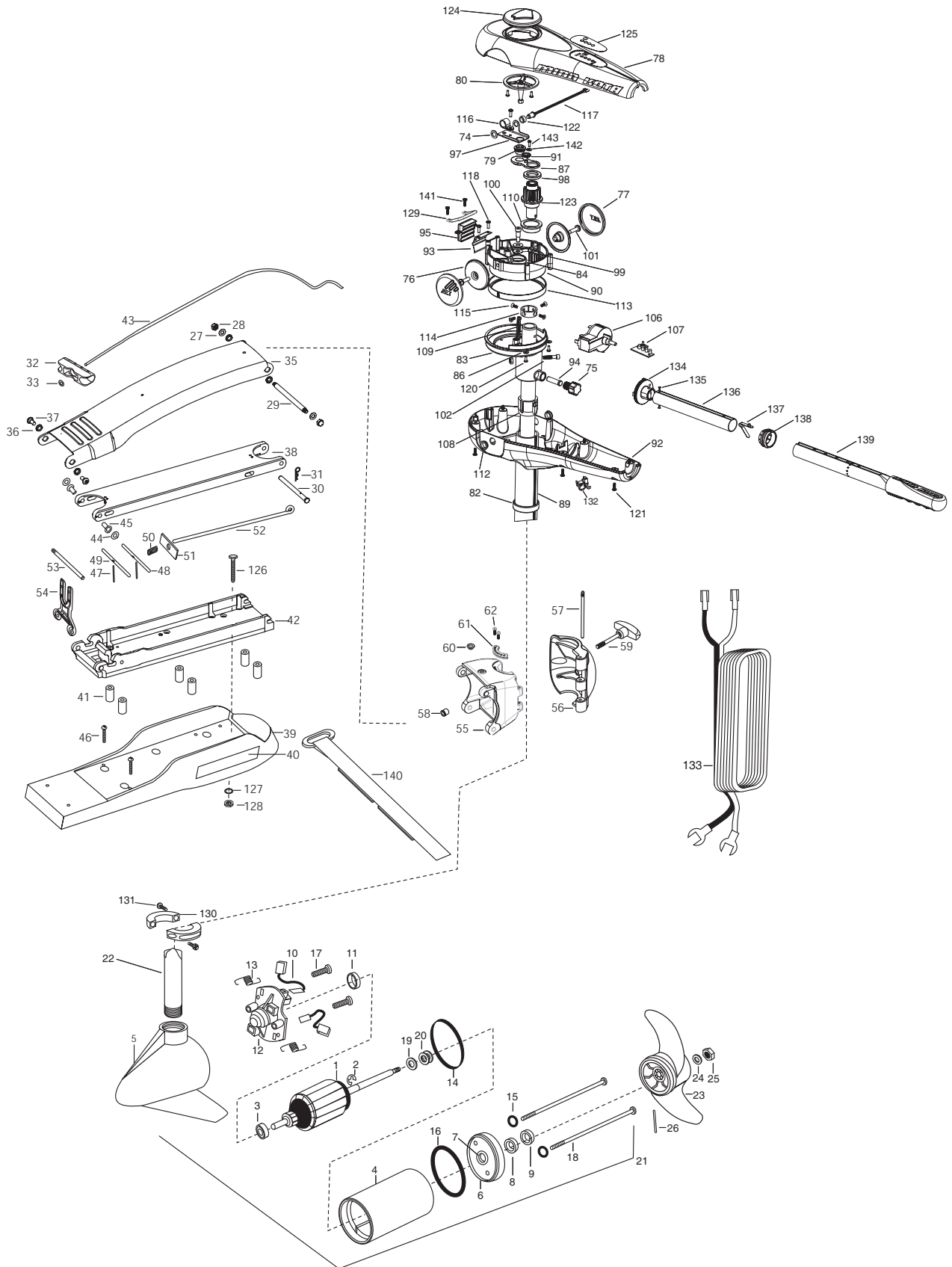

1	2-100-119	ARMATURE ASSEMBLY 24V 3.625 5SPC 65#	43	2251601	ROPE (40"), MAXXUM MOUNT	98	2073000	RING PRELOAD
2	788-015	RETAINING RING	44	2261707	WASHER-3/8X1/2X.010" SS [2.EA]	99	2073100	HEX NUT - NYLOC [3 EA.]
3	140-010	BALL BEARING	45	2236000	BEARING NYLINER-[2.EA]	100	2073400	SCREW 5/16" X 1/2" SHOULDER
4	2-200-304	CENTER HOUSING ASSEMBLY 3.625 FW TXT	46	2263434	SCREW, 8-18 X 1" PPH SS [2.EA]	101	2073408	SCREW [2 EA.]
5	2-300-338	BRUSH END HOUSING ASSEMBLY 3.62 SPCO	47	2152612	SPRING-PIN LOCKBAR [2.EA]	102	2073410	SCREW
6	2-400-337	PLAIN END HOUSING ASSEMBLY	48	2233621	LOCK BAR- BOW MOUNT	106	2064023	SWITCH 5 SPD FOR / REV
7	144-049	BEARING - FLANGE (SERVICE ONLY)	49	2233623	LOCK BAR, REAR - SS	107	2074081	BATTERY METER
8	880-003	SEAL	50	2152701	SPRING-LOCKBAR-SS	108	2075100	TENSION SLEEVE
9	880-006	SEAL WITH SHIELD	51	2262703	SPRING STOP	109	2076701	KEY - TUBE
10	188-036	BRUSH ASSEMBLY [2.EA]	52	2153603	EYE SHAFT-2LOCKBAR STD-SS	110	2077305	BEARING UPPER
11	725-050	BRUSH RETENTION- PAPER TUBE	53	2260505	HINGE-PIN HEADLESS-SS	112	2077316	BUSHING [2 EA.]
12	738-036	BRUSH PLATE W/HOLDER	54	2293811	YOKE,MAX MNT-POLYPROPYLENE	113	2077320	BEARING - GEAR CARRIER
13	975-040	SPRING - TORSION [2.EA]	■	2881828	HINGE BASE/INSERT ASSEMBLY	114	2071560	COLLAR TUBE
14	337-036	GASKET	55	2991828	HINGE BASE	115	2223468	SCREW 8-32 [4 EA.]
15	701-008	O-RING, THRU-BOLT [2.EA]	56	2261859	HINGE DOOR-SW TEXT. WHT	116	2263201	CLAMP WIRE HARNESS
16	701-081	O-RING	57	2262642	PIN-HINGE DOOR, RT HNG/DOOR	117	2264015	LIGHT INDICATOR
17	830-007	SCREW-8-32 [2.EA]	58	2264706	INSERT-HINGE BASE (STD. MNT.)	118	2372100	SCREW 8-18 SS [2 EA.]
18	830-008	THRU-BOLT 10-32X9.205" [2.EA]	59	2260186	KNOB-HINGE COVER SW SS	120	2332103	SCREW 6-20 SS [5 EA.]
19	990-067	WASHER- STEEL THRUST	60	2262315	EYELET ROPE SS	121	2012100	SCREW 8-18 X 5/8" [6 EA.]
20	990-070	WASHER - NYLATRON [3.EA]	■	2994845	ORIENTATION RING BAG ASSEMBLY	122	2071525	SPACER-INDICATOR LIGHT
21	2096040	MOTOR ASSEMBLY 24V 3.62 5 SPD SW			(INCLUDES ITEMS 61, 62 AND HEX WRENCH)	123	2992205	PINION - MAIN
22	2072011	TUBE- COMPOSITE 3:1 52" SW WHT	61	2072825	ORIENTATION RING	124	2998601	INDICATOR ASSEMBLY
■	1378131	PROPELLER KIT	62	2073416	SCREW #8-322 X 1/2" SSSC [2 EA.]	125	2075633	DECAL VECTOR 70
23	2091160	PROPELLER W/WEDGE 2	74	2013100	SPEED NUT	■	2994830	BAG ASSEMBLY - MAXXUM VECTOR
24	2151726	WASHER-5/16 SS	75	2070105	KNOB-TENSION SLEEVE	*126	2263431	1/4-20X3.5" PPH [6.EA]
25	2198400	ANODE	76	2070110	PIVOT KNOB [2 EA.]	*127	2261713	WASHER 1/4 FLAT SS [6.EA]
26	2092600	PIN-DRIVE	77	2070118	COVER-PIVOT KNOB [2 EA.]	*128	2263103	NUT 1/4-20 NYLOC-JAM SS [6.EA]
27	2261722	WASHER 1/4 FLAT [2.EA]	78	2070206	COVER 3:1	129	2072815	BRACKET- TILT STOP
28	2223100	NUT- TENSION 5/16-18 SS [2 EA]	79	2070800	COUPLER SOCKET	130	2261622	COLLAR HALF [2 EA.]
29	2262604	PIN- BWGRD UPPER THREADED	80	2070810	COUPLER DRIVE	131	2263453	SCREW 1/4-20 X1" [2 EA.]
30	2262606	CLEVIS PIN ZP MAXXUM BWGRD	82	2071500	COLLAR-LOWER SUPPORT	132	2052900	STRAIN RELIEF
31	2260800	SPRING CLIP S/S	83	2071513	YOKE-PIVOT [2 EA.]	133	2090650	LEADWIRE
32	2150400	PULL-GRIP	84	2071710	WASHER NYLATRON	134	2070406	PIVOT HANDLE ASSEMBLY
33	2151700	WASHER-EYE SHAFT(.562 OD)	85	2071712	WASHER SS	135	2072102	SCREW #6 X 1/4" [2 EA.]
■	2991857	MOUNT, BOW ASSEMBLY W/HINGE	86	2071714	WASHER FLAT #6 [2 EA.]	136	2070425	HANDLE TUBE
■	2771828	HINGE BASE/BOWMOUNT ASSEMBLY	87	2071900	IDLER PLATE	137	2070411	LATCH-BUTTON
35	2264244	ARM-UPPER SW STD	89	2072091	OUTER TUBE 3:1 52"	138	2070010	BEARING
36	2293501	BUSHING, STAINLESS STEEL [4.EA]	90	2072210	GEAR CARRIER	139	2990935A	HANDLE ASSEMBLY-EXT.
37	2263500	BOLT- SHOULDER (MAXXUM) [2.EA]	91	2072215	GEAR- IDLER	140	2263804	STRAP-HOLD DOWN
38	2994310	ARM-LOWER ASSEMBLY, STD,SW	92	2072502	CONTROL BOX	141	2332101	SCREW #8-32 X 1/2" SS [2 EA.]
39	2263914	MOTOR REST STD MAXXUM	93	2072705	SPRING DETENT	142	2071720	#4 WASHER SS
40	2065676	DECAL-MAXXUM,MOTOR REST [2.EA]	94	2072710	SPRING TENSION SLEEVE	143	2373440	#4 SCREW SS
41	2261505	SPACER, MOTOR REST [6.EA]	95	2072810	DETENT BLOCK-TILT			
42	2993983	BOWPLATE,STD SW-MACH/INSERT	97	2072900	RETAINER COUPLER			

